

OPERATING INSTRUCTIONS

KRUSE Fire Brigade KeyDepot (FSD) basic



Contents

1. Description	4
2. List of abbreviations.....	4
3. About these operating instructions.....	4
3.1 Explanation of symbols and instructions.....	5
3.2 Presentation conventions.....	5
3.3 Target group	5
3.4 Applicable documents.....	5
4. Product information.....	6
4.1 Product name and type designation	6
4.2 Manufacturer information.....	6
5. Safety	6
5.1 Intended use.....	6
5.2 Foreseeable misuse	6
5.3 Labelling on the product	6
5.4 Safety instructions for installation, operation and maintenance.....	8
6. Product description	10
6.1 Function of the product	11
6.2 Main components	11
6.3 Technical Data.....	13
Dimensions	13
Maximum installation length of the OSÜ.....	14
Requirements for the installation location.....	15
Electrical connection	15
Examples of connections	16
Environmental conditions.....	17
7. Transport	17
7.1 Package contents	17
7.2 Packaging	17
7.3 Symbols used on packaging	17
7.4 Delivery.....	17

8. Assembly.....	18
8.1 Delivery.....	18
8.2 Mount the product at the installation location (mounting directly in the wall).....	18
8.3 Remove OSÜ in FSD basic	20
8.4 Flange FSD (or unflange for replacement).....	21
8.5 Fasten the frame	21
8.6 Check correct assembly and installation.....	22
9. Maintenance and repair	22
9.1 Clean outer surfaces	22
9.2 Maintenance plan	23
9.3 Replace profile semi-cylinder	24
10. Possible operational malfunctions	25
11. Decommissioning and disposal.....	26
11.1 Decommission product.....	26
11.2 Information on disposal	26
11.3 Disposal points.....	26
12. Service.....	27
12.1 Order details.....	27
12.2 Accessories	27
12.3 Dimensions of accessories (in millimetres).....	27
12.4 Spare parts	28
12.5 Product specifications.....	28
Electrical specifications	29
12.6 Support	29
13. FSD operation Information.....	29
14. Edits index.....	29
15. Questions left?	29
<i>APPENDIX A: VdS 5005.....</i>	<i>30</i>
<i>APPENDIX B: Wiring diagram.....</i>	<i>32</i>

1. Description

The KRUSE Fire Brigade KeyDepot basic is the security standard when it comes to theft-proof and easy-to-manage key storage. In the event of a fire or alarm, the local fire brigade has quick access to the object key, which is stored inside and allows non-violent access to the object.

2. List of abbreviations

BMZ	Fire alarm control panel
DIN	Deutsches Institut für Normung (German Institute for Standardisation)
E-opener	Electric opener; electric break contact
FSD	Fire brigade KeyDepot
FB	Fire brigade
OL	Orientation light
OSÜ	Object key monitoring
SD adapter	KeyDepot adapter
VDE	Verband der Elektrotechnik Elektronik Informationstechnik e. V. (Association for Electrical Electronic & Information Technologies e. V.)
VdS	Verband der Sachversicherer (Association of Property Insurers)

3. About these operating instructions

This operating manual contains information and instructions necessary for the safe operation of the product.

- Read these operating instructions thoroughly before the first operation.
- Keep the operating instructions in an easily accessible place in order to have them available as a reference work at all times.
- Follow the instructions in this manual when using this product.
- Carry out regular maintenance according to the operating instructions.

3.1 Explanation of symbols and instructions



WARNING

This symbol indicates a potential immediate danger to the life and health of persons. Failure to follow these instructions can result in serious health damage or even life-threatening injuries.



CAUTION

This symbol indicates a potentially hazardous situation. Failure to follow these instructions may cause minor injuries or damage to property.



NOTE

This symbol provides important information for the correct handling of the product. Failure to follow these instructions may result in property damage.

3.2 Presentation conventions

Highlight in text

To simplify the readability and overview, various paragraphs/information are/is highlighted. These symbols have the following meanings:

- 1) Carry out instructions one after the other in the order described.
- 1.1) Carry out subordinate instructions in the order described.
- Bulleted.

Key figures

If necessary, texts are illustrated with images. An image caption is located below the image. The reference from the text to a position in the image is made by a set position number.

Images

The images in this operating manual are for illustrative purposes and may differ from the actual delivery condition of the product.

Measurements

All measurements in images and dimensioned drawings are in millimetres.

3.3 Target group

These operating instructions are intended for the following personnel of a certified installer:

- Installation personnel
- Operator
- Maintenance personnel

3.4 Applicable documents

The other applicable documents contain technical documents with further information. They are an integral part of the technical documentation.

KRUSE Sicherheitssysteme GmbH & Co. KG provides the supplier documentation of assemblies that have only been further processed when delivery.

We reserve the right to make technical modifications
07/2024

4. Product information

4.1 Product name and type designation

Product name	Fire Brigade KeyDepot
Product type	FSD basic

4.2 Manufacturer information

Name	KRUSE Sicherheitssysteme GmbH & Co. KG
Address:	Duvendahl 92, 21435 Stelle, Germany
Email:	vertrieb@kruse-sicherheit.de
Phone:	+49 4174 592-22

5. Safety

All persons who operate the product must have fully read and understood these operating instructions, and particularly the safety chapter. The rules and regulations applicable to the site for accident prevention and environmental protection must also be observed by operators and operating personnel.

5.1 Intended use

The KRUSE Fire Brigade KeyDepot basic is used to hand over object keys to the fire brigade in the event of an emergency. The provisions of the respectively valid versions of VdS guidelines 2350 and 2105 apply to the installation and operation. Operation is only possible by means of a hazard detection system. Installation and commissioning must be carried out by a certified VdS installer.

5.2 Foreseeable misuse

The product may only be operated with the parameters, materials and accessories specified by the manufacturer. In addition, the following applications are considered misuse:

- Independent conversion or repair measures
- Bridging or overriding safety devices
- Improper use of accessories or connected devices

5.3 Labelling on the product

Labels are attached to the product that provide further information and warn of hazards in handling the product. The labels must be kept in an easily legible condition for the entire service life of the product and must be replaced immediately in the event of damage. For unreadable labels, contact customer service.





Nameplate

The nameplate is located above the door latch inside the FSD and contains the following information:

- Manufacturer's name
- Type designation of the product
- CE label
- Serial number
- VdS test number
- Construction year
- Product specifications

Warning and notice signs

There are warning and information signs on the product, which are attached to the respective hazardous areas of the product. The meaning of the warning and information signs can be found in the following table:

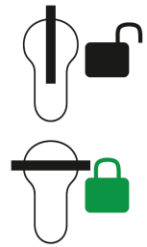
Symbol	Description
	Orientation arrows: "This side up"
	VdS-approved
	Potential equalisation
	Note: "Warning! Do not remove the latch lock without first checking the function of the electric opener."
	Note: "Object key secured" Meaning: The object key(s) is/are secured
	Note: Key vertical: unsecured Key horizontal: secured

We reserve the right to make technical modifications
07/2024

5.4 Safety instructions for installation, operation and maintenance

General safety instructions

- Assembly may only be carried out by qualified personnel.
- Installation by at least two people.
- The components may fall during assembly.
- Wear protective gloves and safety shoes.
- Select a suitable installation location.



Personnel

- Work on the product may only be carried out by trained and instructed specialist personnel of an installer company certified in accordance with DIN 14675:2020-01 (for example VdS).

Hazard due to electrical system

- The product may only be operated with the electrical connection specifications specified in the technical data.
- The product may only be connected via a multicore cable (LIYY 10 x 0.5 mm²). For exceptions, see VdS 2023-06 (06).
- In the event of a short circuit, there may be sparks.

Assembly

Assembly must be carried out by qualified personnel in accordance with the assembly instructions for FSD from the VdS guidelines VdS 2350:2023-06 and the regulations resulting from these assembly/operating instructions. Different types of installation may be possible via a special approval after testing by the VdS.

Closure

Only VdS-approved locks may be used for locking the inner door (in accordance with VdS guideline 2350:2023-06).

Operation

- Operate the product only in the permissible ambient conditions.
- When the heater is switched on, a short-term component-related inrush current of a multiple of the rated current may occur (see point 12.5 "Product Data – Electrical specifications"). Operate the heater on a short-circuit-proof, separate power supply unit (recommended: KRUSE item no. 500300).
- The continuous power supply of the integrated heater must be ensured via a low-voltage circuit (in accordance with VdS guideline 2350:2023-06). An uninterruptible power supply is not necessary.

Cleaning & maintenance

Do not clean the product with aggressive or abrasive cleaning agents. The KRUSE stainless steel cleaning and care set (item no. 520600) is recommended.

Maintenance and repair

- All inspections for maintenance, repair and inspection work must be documented in the operating book of the respective hazard detection system.
- Maintenance work may cause the alarm to be triggered.
- After completion of all work on the FSD and its system components, proper function must be restored.

Duties of care of the operator

For safe operation, the operator of the product must comply with the following obligations:

- Carry out regular maintenance and testing of the product.
- Carry out safety instructions.
- Conduct training on how to handle the product.
- Always make the operating instructions accessible to personnel.

Duties of care of the installation personnel

For safe operation, the installation personnel must comply with the following obligations:

- Read and follow full instructions.
- Carefully read and observe safety data sheets and regulations.
- Observe the basic rules for safety at work and accident prevention.
- Wear personal protective equipment (safety shoes, protective gloves, protective clothing).
- Read and understand all safety instructions in this operating manual.

6. Product description

This chapter provides information about the structure and function of the product, its main components and the technical data.

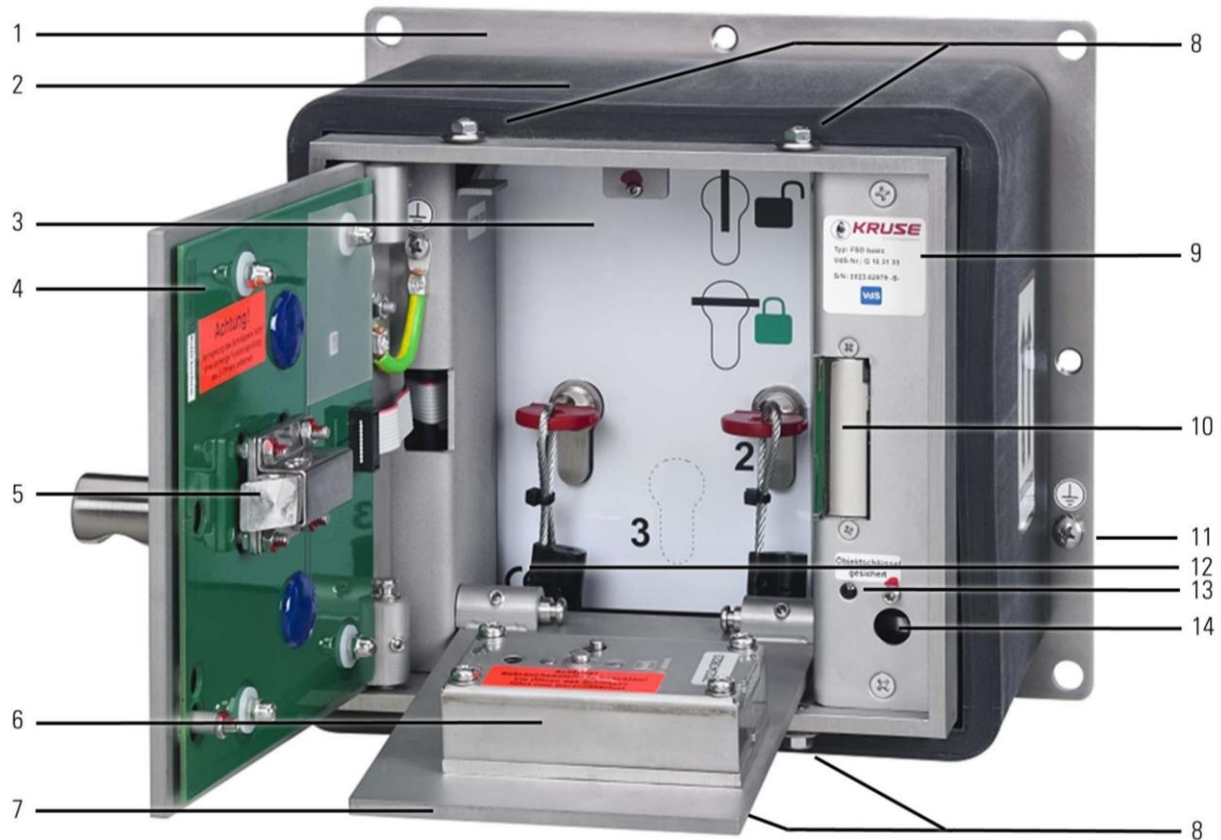

Figure 1: FSD (Art. 500006K)

1	Mounting flange	8	Clamping pieces for the frame (4x)
2	FSD body (optional with anti-tamper protection)	9	Nameplate
3	OSÜ-plate	10	Door lock (E-opener)
4	Drilling protection board with heating	11	Potential equalisation
5	External door locking mechanism (latch)	12	CE label
6	Fire brigade lock (depends on model)	13	Object key status display
7	Inner door	14	Door contact outer door

We reserve the right to make technical modifications
07/2024

6.1 Function of the product

The FSD basic is intended for theft-proof, tamper-proof storage of object keys. When an alarm is triggered by the connected fire alarm system or burglar alarm system, the external door of the FSD is released so that the fire brigade can access the property without using force. The FSD is controlled and monitored exclusively via VdS-approved key-depot connections or VdS-approved key-depot adapters and release elements. The activation in an emergency may only take place via VdS-approved release elements. Products of KRUSE are recommended.

6.2 Main components

See figure 1: The FSD basic consists of the FSD body (2), the OSÜ (3) and the inner door with fire brigade closure (7).

FSD body

The body of the product serves as a robust housing for the electronics, the OSÜ and the inner door with fire brigade closure. The FSD body has a heated outer door at the front and is attached via the mounting flange located at the rear.

OSÜ-plate

The OSÜ-plate is in the FSD body. Upon delivery, the OSÜ is equipped with auxiliary cylinders and the corresponding keys on which the object keys can be permanently secured VdS-compliant via a seal. A third OSÜ can be ordered with the FSD or be expanded afterwards.

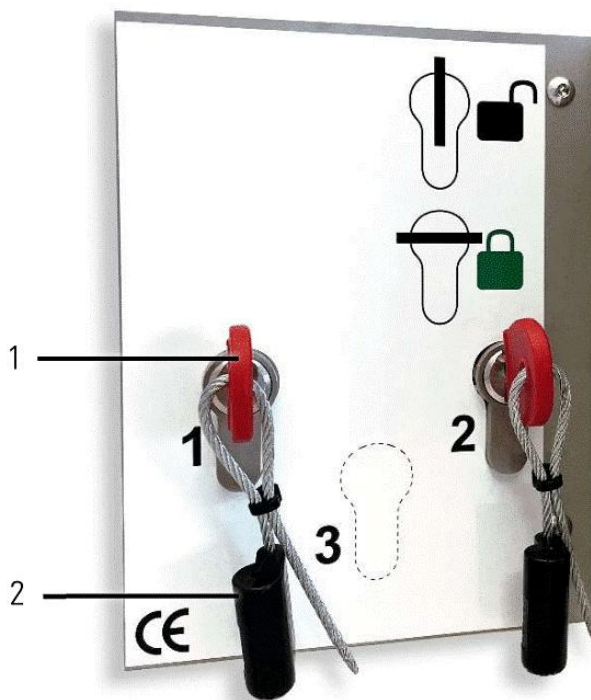

Figure 2: OSÜ (example, exact arrangement may vary)

1	OSÜ: Auxiliary cylinder with key
2	Fuse cable with seal for permanent attachment of the object keys

Connect OSÜ to the transfer board

- 1) Mount the microswitch to the OSÜ plate.
- 2) Connect the plug from the microswitch to the next free slot on the transfer board.
The slots X1-n are located in the monitoring line of the FSD. The slots X2-n are intended for external key monitoring and are not integrated in the monitoring line.
- 3) Remove the zero-ohm resistor next to the selected slot. For slot X1-2 → resistor R2 etc.
- 4) Set the profile cylinder locking nose. The locking nose must be at 12 o'clock when the key is removed.
- 5) Mount the profile cylinder on the OSÜ plate.

Name	Description
X1-A	Connection to transfer board
X1-1	1. OSÜ
X1-2	2. OSÜ
X1-3	3. OSÜ
X1-4	4. OSÜ

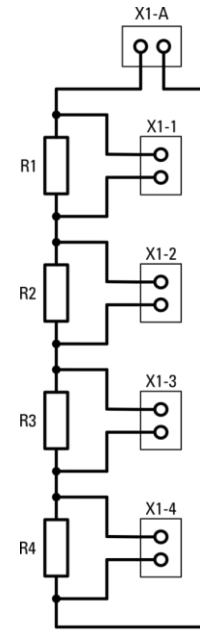
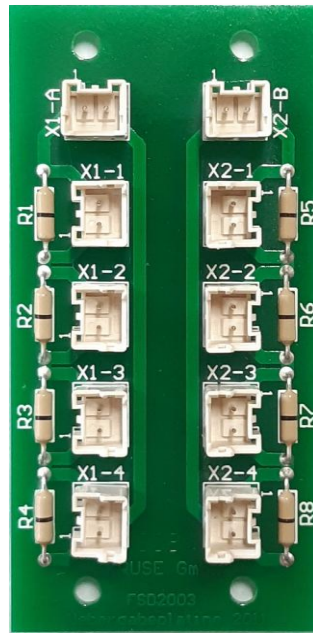

R1, R2, R3, R4 = 0 Ohm

Figures 3, 4: Transfer board

Component overview on the connection board

Name	Description
SV1	Optional; external OSÜ, led out of the depot to green/yellow
SV2	Drilling protection board of the outer door with heating
SV3	Supply voltage for additional boards
SV4	E-opener with feedback contact (door closed = feedback contact open)
SV4A1	Lighting assembly
SV4B1	Object key status display
SV5	Door contact outer door
SV6	First OSÜ
SV7	Second OSÜ – only for older FSD models without transfer board. To activate, remove zero-ohm resistor R3.
SV8	Anti-tamper protection
(SV9)	(Card monitoring; only for FSD flex-L, not basic)

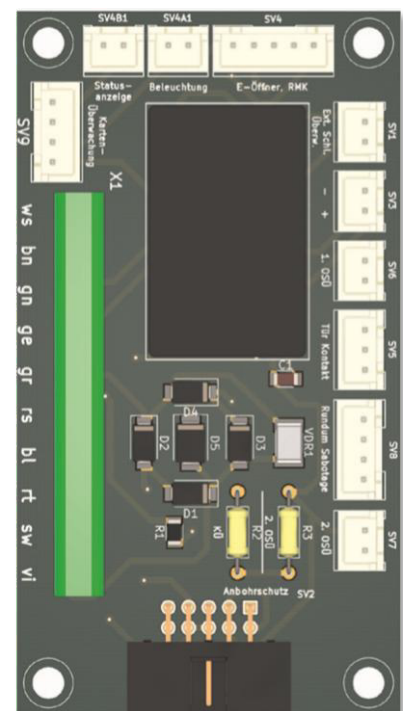
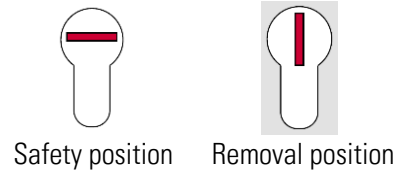

Figure 5: Connection board

We reserve the right to make technical modifications
07/2024

Key positions

See figure 1: At the FSD body you find the object key status display (13) showing the current status of the keys to be secured. If it lights **green**, all keys are in safety position. If it is **off**, at least one key is **not** in safety position.



6.3 Technical Data

Dimensions

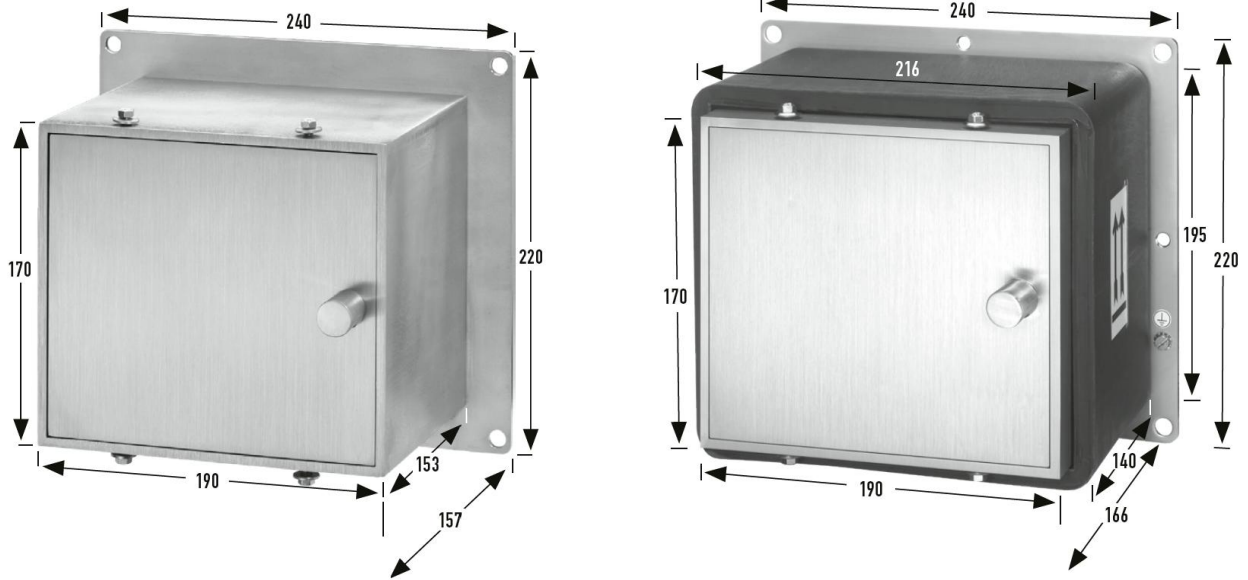

Figures 4 and 5: Dimensions FSD basic with/without all-round sabotage protection (in millimetres)

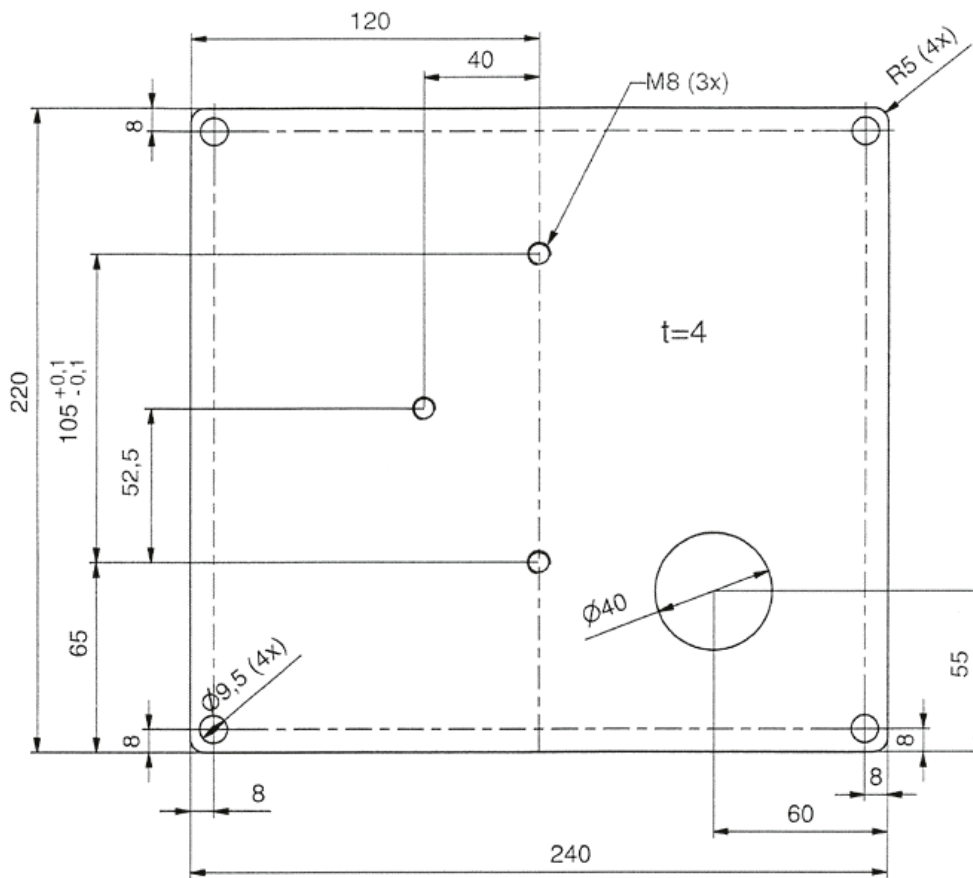

Figure 6: Mounting flange dimensions (in millimetres)

We reserve the right to make technical modifications
07/2024

Maximum installation length of the OSÜ

Static OSÜ variants:

Maximum combined length (cylinder incl. key) 101 mm for all three possible keys (C).

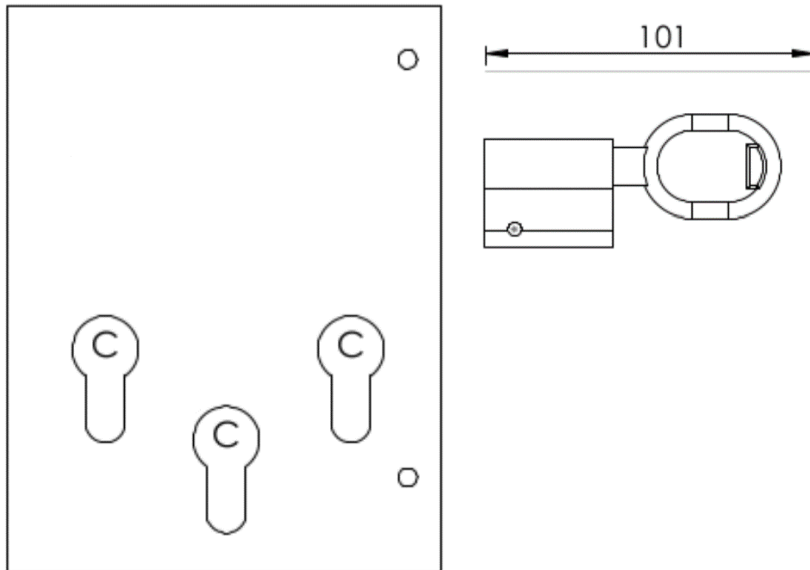

Swivel plate OSÜ variants:

Different installation depths due to position.

Maximum combined length 93 mm (e.g. electronic cylinders such as Verso Cliq) for keys on the left (A).

Maximum combined length 71 mm (standard half cylinders) for keys on the right (B).

Dimensions of the profile cylinders used 30/10mm, according to DIN 18252.

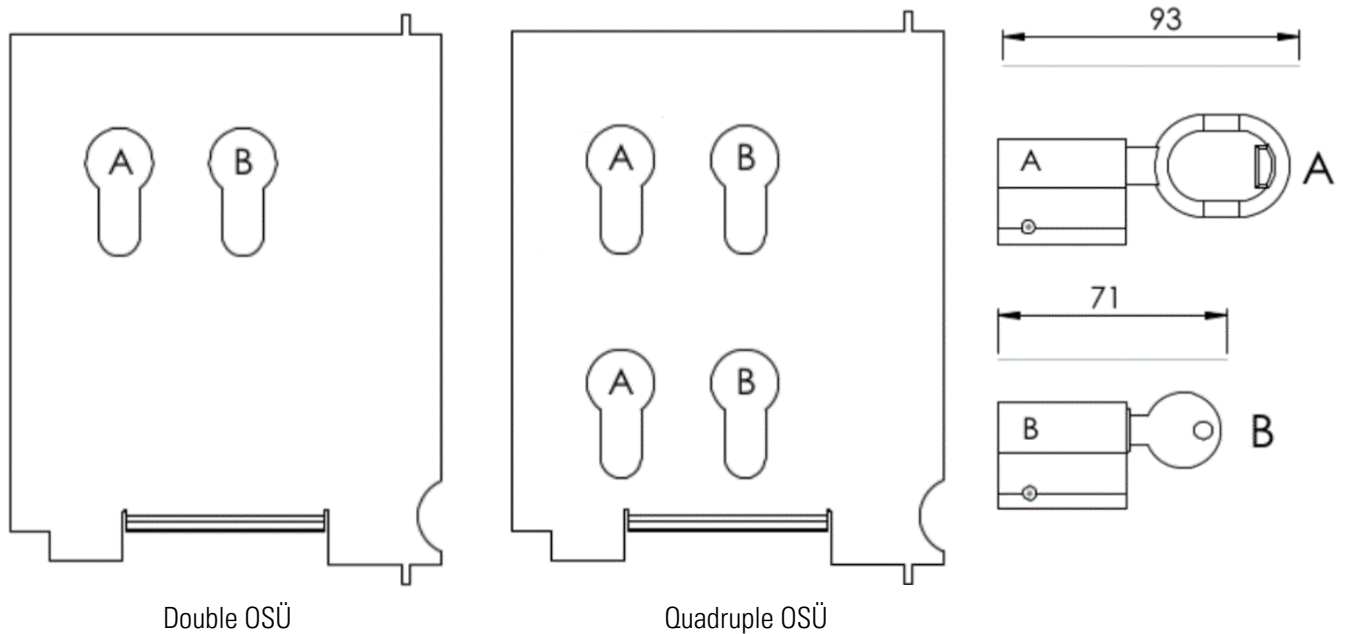

NOTE

In the swivel plate OSÜ variants, cylinders with a combined length of 93 mm at position A may suffer functional impairments if a key seal (e. g. KRUSE KeySeal) is used.

We reserve the right to make technical modifications
07/2024

Requirements for the installation location

The FSD is intended for installation in the following wall only:

- Masonry according to DIN 1053/brick according to DIN 105/sand-lime brick according to DIN 106.
- Reinforced concrete according to DIN 1045 (at least B 25).
- Minimum installation height (lower edge): 0.8 m above the ground. Maximum installation height: 1.4 m above the ground.
- Recommended installation height (bottom edge): 1.2 m above the ground.
- The FSD must be walled in with mortar to DIN 1053 or poured into the concrete wall.
- Protect the installation site from precipitation, mount preferably in a weather-protected area, with rain protection if necessary.



NOTE

For VdS-compliant installation, the VdS 2350 guideline must be observed. If not all individual requirements can be met, there is the possibility for special/individual approvals by the VdS. For technical advice, please contact our sales department at: vertrieb@kruse-sicherheit.de

Electrical connection

- When using supply lines that are longer than 50 m, the line resistance must be compensated by appropriate cross-sectional enlargement in order to be able to operate the FSD with the necessary supply voltage. The standard DIN VDE 0891-6 must be observed. **The required cross-section should be determined by a qualified electrician.**
- The heating of the FSD must be connected and always ready for operation. Optionally, you can get a plug-in power supply (KRUSE item no. 500300) or a DIN rail power supply (KRUSE item no. 500310).
- Connect potential equalisation conductor (according to VdS 2350; min. 4 mm²).

Examples of connections

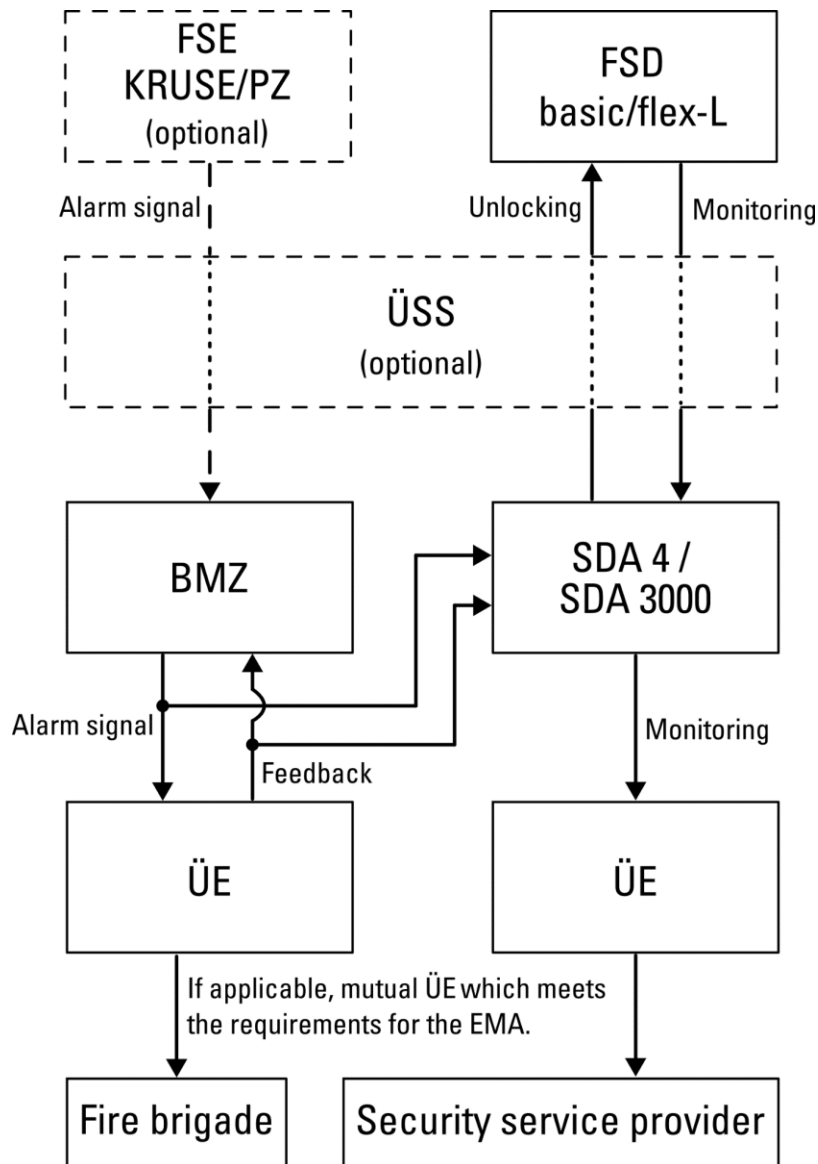

For more examples of connections, see VdS 2350:2023-06

We reserve the right to make technical modifications
07/2024

Environmental conditions

Operation of the product is only permitted in a dust- and vapour-free, non-corrosive atmosphere. The product is not suitable for use in potentially explosive atmospheres.

Admissible environmental temperature	-23 to +50 ° Celsius
Admissible relative humidity	< 95 % (not condensing)

7. Transport

This chapter provides information on the transport and handling of the package.

7.1 Package contents

Upon delivery of the product, the following components are included pre-assembled:

- ✓ Interior door (prepared for profile semi-cylinder [30 mm] or incl. VdS conversion lock/Mauer conversion lock)
- ✓ Frame
- ✓ Mounting flange
- ✓ Included in the package: label for key with alternative trigger position
- ✓ 10 m electric cable
- ✓ OSÜ with two auxiliary cylinders for monitoring
- ✓ Object key status display
- ✓ KRUSE KeySeals
- ✓ Heavy load dowels
- ✓ Operating instructions

7.2 Packaging

The packaging is a transport packaging for shipping from the manufacturer to the customer. It protects the product under normal use by transport companies. Please check the packaging immediately for transport damage when accepting the goods.

7.3 Symbols used on packaging



NOTE

Observe symbols and instructions on the packaging. If you have any questions or are unsure, do not carry out any work and contact the manufacturer.

7.4 Delivery

The packages are packaged according to requirements.

Upon delivery, the following points must be checked:

- ✓ Completeness of the packages.
- ✓ Integrity of the packaging and all components contained therein.
- ✓ Completeness and accuracy of the delivery documents.
- ✓ In the event of defects in the product or the delivery documents, report them immediately to the manufacturer and the responsible shipping agent and document them on the transport documents.

8. Assembly

The product is delivered pre-assembled and can now be attached at the place of use.

8.1 Delivery

Before installing the FSD, ensure or check the following points:

- ✓ Proper laying of the incoming and outgoing cabling.
- ✓ Compliance with the requirements for the installation location (see point 6 "Technical data", "Requirements for the installation location").
- ✓ Sufficient space for assembly and operation.
- ✓ Wall frame is installed in accordance with the associated assembly instructions, if it is used.
- ✓ With use of a KRUSE conversion lock or profile semi-cylinder, the threaded pin for the doorstop is screwed in.

8.2 Mount the product at the installation location (mounting directly in the wall)



WARNING

Assembly may only be carried out by qualified, DIN 14675:2020-01-certified specialists.

- 1) Determine the required installation depth at which the front of the FSD is flush with the facade. Recess for cable laying must be considered.
- 2) Mount the segment anchors (see the installation instructions for the segment anchors).
- 3) Loosen nuts of segment anchors and screw (if necessary) enclosed half nuts onto the segment anchors for depth positioning.
- 4) Screw the supplied nuts onto the threaded bolts at the determined installation depth.
- 5) Route the wiring through the recess in the wall.
- 6) Connect the potential equalisation.
- 7) Place the product with the mounting flange on the threaded bolts (Fig. 1, next page).
- 8) Place the spring washers on the threaded bolts and screw on the shear nuts.
- 9) Tighten the shear nuts until they break at the predetermined breaking point and the cone remains on the threaded bolts.
- 10) Integrate the product into the alarm system according to the wiring diagram (see Appendix C, last page).
- 11) Fill the space between the FSD and the masonry with mortar (observe the following note).



NOTE

Avoid the clamping pieces for the frame when filling the free space (Fig. 2, next page)!

The mortar used must meet the requirements of DIN 1053.

- 12) The product is now firmly connected to the masonry and integrated into the hazard detection system.

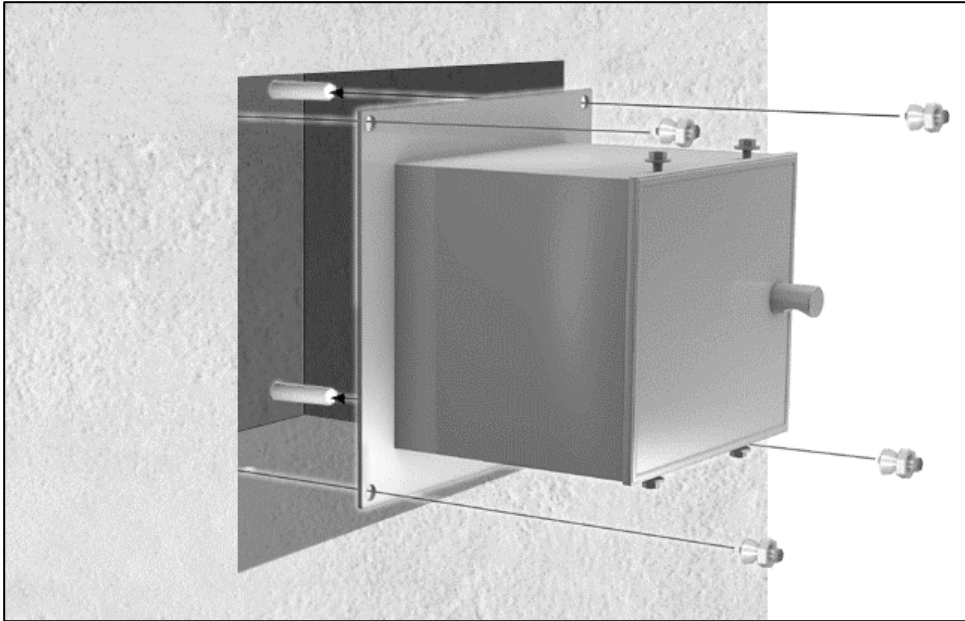

Figure 1: Install FSD

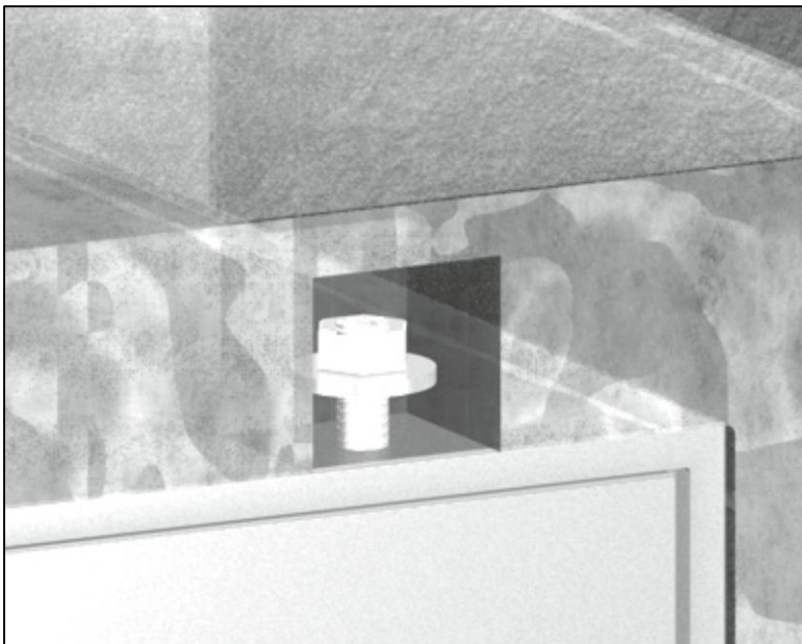

Figure 2: Recess for fixing screws

We reserve the right to make technical modifications
07/2024

8.3 Remove OSÜ in FSD basic

Rigid OSÜ

Here it is sufficient to loosen the two screws on the right side of the OSÜ.

Swivel plate OSÜ

First remove the interior door of the FSD. Then disassemble the OSÜ plate. To do this, loosen the visible screws (Fig. 1) and push the locking pin downwards (Fig. 2). Tilt the plate forward (Fig. 3) and disconnect the plug (X1-A and, if necessary, X2-B) from the rear transfer board (Fig. 4).

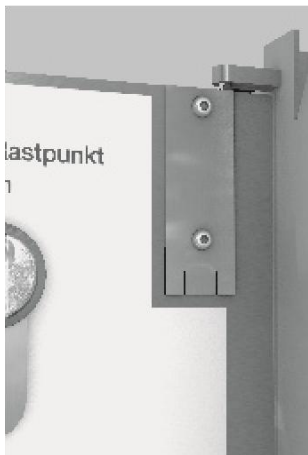

Fig. 1

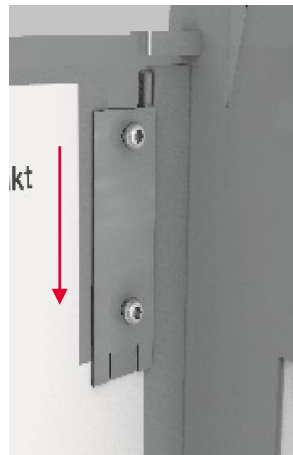

Fig. 2

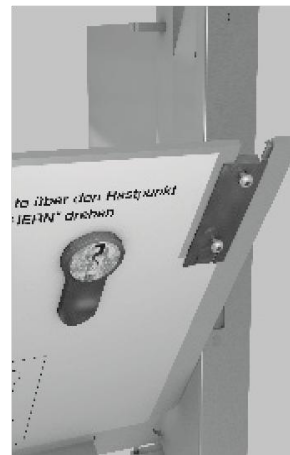

Fig. 3



Fig. 4

8.4 Flange FSD (or unflange for replacement)

- The FSD is connected to the mounting flange with three countersunk screws located on the rear wall. These are accessible through the interior of the FSD (Figure 1).
- For the FSD with all-round sabotage protection, M8 x 20 TORX 45 countersunk screws are used, for the FSD without all-round sabotage protection, M8 x 12 TORX 45 countersunk screws.
- In advance, the inner door and OSÜ are removed (see point 8.3 "Remove OSÜ in FSD basic"), then the FSD can be flanged (or unflanged for an exchange of the FSD) by means of the three screws with 30 Nm.

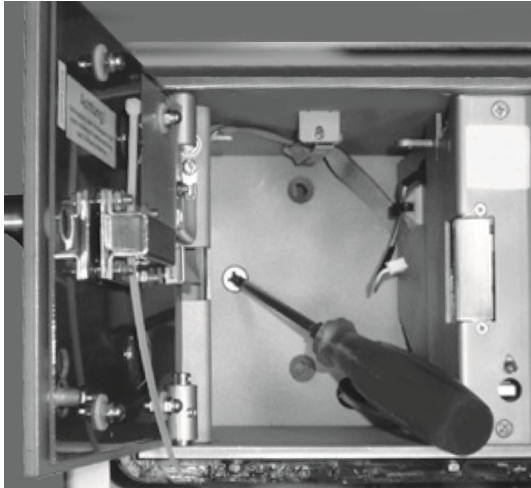

Figure 1: Three fixing screws on the rear panel

8.5 Fasten the frame

- 1) Insert the clamping pieces of the frame (4 x) into the threads provided.
- 2) Align the frame with the recesses on the clamping pieces and place it until it is completely flush with the facade.
- 3) Open the outer door via the hazard alarm system.
- 4) Tighten the clamping pieces from the inside with a 2.5 mm hexagon wrench (Figure 2).
- 5) The frame is fixed.



Figure 2: Position of the clamping pieces for the frame

8.6 Check correct assembly and installation



NOTE

To carry out the following activities, access via the fire brigade closure of the inner door is necessary. The person holding the relevant key must be present.

After installing the FSD, the following tests must be carried out:

- 1) Check proper release of the external door via control by the fire alarm system.
- 2) Check the inner door with the fire brigade lock for ease of movement and correct closure.
- 3) Check the ease of the key extraction of each profile semi-cylinder.
- 4) Check the function of the object key status display.
- 5) Turn one key at a time to the non-secured position and make sure that the LED of the status indicator goes out.

All keys are in secured position: LED lights **green**. At least one key is not in secured position: LED **off**.

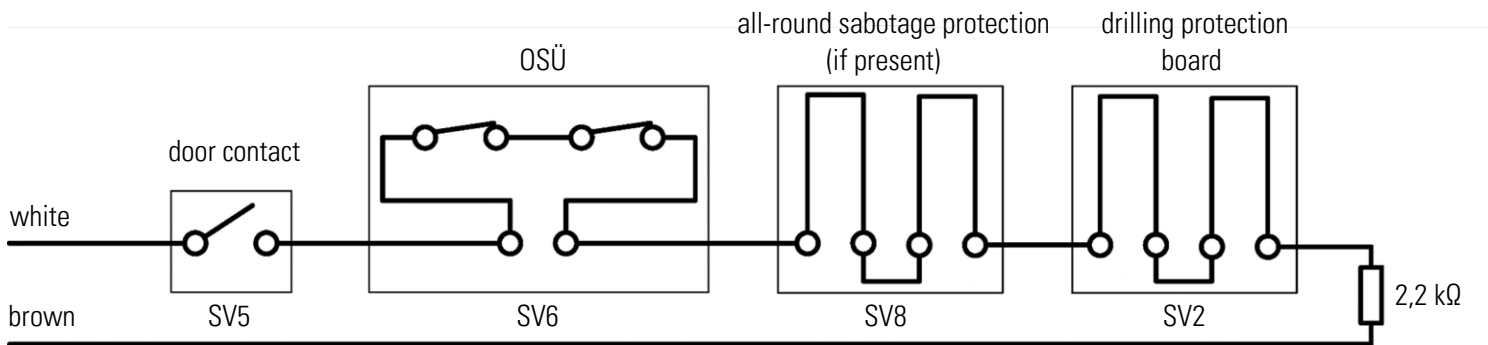

Figure 1: Simplified representation of the primary line

9. Maintenance and repair

9.1 Clean outer surfaces



NOTE

Do not use aggressive or abrasive cleaning agents for cleaning. The KRUSE stainless steel cleaning and care set is suitable (Art. 520600). Do not use with colour coatings!

All 3 months, the outer surfaces must be cleaned:

- 1) Clean outer surfaces with a soft and clean cloth.
- 2) Now treat with a suitable care product.

9.2 Maintenance plan



NOTE

To carry out the following activities, access via the fire brigade closure of the inner door is necessary. The person holding the relevant key must be present.

All 3 months, the FSD is to be subjected to the following tests:

- ✓ External integrity of the FSD and its system components.
- ✓ Function of the opening monitoring (electrical and mechanical).
- ✓ Function of the E-opener as well as its feedback contact.
- ✓ Integrity of the cable transition for area monitoring of the door.
- ✓ Function of FSD in combination with FSD adapter and its displays.
- ✓ Easy mobility and permissible clearance of the external door of the FSD.

Once a year, the FSD must undergo the following tests:

- ✓ Check the function of the e-opener of the external door.
- ✓ Check the function of the heater (usually only the heating element on the top left becomes warm; the second element serves as a replacement).
- ✓ Check the function of the OSÜ: Remove the object key and check the indicator light. Try to lock the FSD without the key. This should no longer be possible.
- ✓ Check the ease of mobility and permissible clearance of the inner door of the FSD.

If the clearance of the inner door of the FSD needs to be adjusted, perform the following steps:

- 1) Open the external door via the fire alarm system.
- 2) Open the inner door with fire brigade closure.
- 3) Adjust the clearance of the inner door via the grub screw.
- 4) Check the inner door for the correct position. Permissible clearance of the inner door: < 1 mm
- 5) The clearance of the inner door is set.

9.3 Replace profile semi-cylinder



NOTE

To carry out the following activities, access via the fire brigade closure of the inner door is necessary. The person holding the relevant key must be present.

Once a year, the condition of the profile semi-cylinder must be tested and possibly be replaced.

To replace a profile semi-cylinder of the OSÜ, take the following steps:

- 1) Remove OSÜ in FSD (see point 8.3 "Remove OSÜ in FSD basic").
- 2) Adjust the locking nose of the new profile semi-cylinder. Locking nose must be at 12 o'clock when the key is removed.
- 3) Loosen the fastening screw with the washer.
- 4) Remove old profile semi-cylinder.
- 5) Insert new profile semi-cylinder.
- 6) Place the washer on the thread of the fastening screw.
- 7) Tighten the fastening screw and check the correct installation position.
- 8) Connect the connector to the transfer board and insert the OSÜ back into the FSD. Readjust the M4 lock nut with grub screw for key extraction.
- 9) Tighten the knurled nuts on the OSÜ.
- 10) Check the function of the object key status display.
- 11) The profile semi-cylinder is replaced.

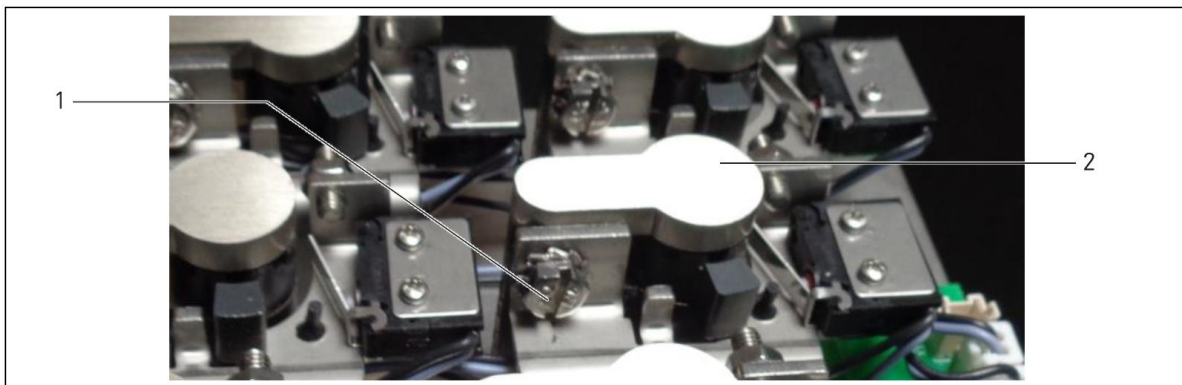

Figure 1: A profile semi-cylinder in the OSÜ unit

1	Mounting screw with washer
2	Profile semi-cylinder

10. Possible operational malfunctions

This chapter explains possible malfunctions. In the event of ambiguities or persistence of malfunctions after attempted troubleshooting, contact our KRUSE support (see point 12.6 "Support").

Operational malfunction	Possible cause	Explanation
SD adapter or BMZ reports FSD sabotage.	<ul style="list-style-type: none"> ➤ Cable breakage in supply line. ➤ External door has too much clearance, the door contact is not operated permanently. ➤ Object key is not clearly in secured position. ➤ Microswitch of door monitoring defective. ➤ Drilling protection board defective. ➤ All-round sabotage protection defective. ➤ Adapter defective. 	The resistance value on the primary line (2.2 kOhm) is below or above the maximum tolerance (for SDA4/SDA3000: +-40 %).
FSD does not open.	<ul style="list-style-type: none"> ➤ Cable breakage in supply line. ➤ External door has no clearance, so the latch presses on the door opener latch. ➤ E-opener defective. 	<p>The FSD normally opens as soon as a voltage of 12/24 V is applied to the grey (-) and pink (+) wires.</p> <p>The BMZ or the SD adapter is responsible for unlocking and locking the FSD.</p> <p>A drilling template for forcibly opening the FSD does not exist.</p>
FSD locks although not all object keys are stored.	<ul style="list-style-type: none"> ➤ Locking nose of a profile cylinder is not set correctly (when the key is removed, the microswitch [NC] must be actuated). ➤ A microswitch socket used on the transfer board of the OSÜ is not armed (zero Ohm resistance next to the socket must be removed). 	<p>The BMZ or the SD adapter is responsible for unlocking and locking the FSD. If all the following criteria are met, it is locked:</p> <ul style="list-style-type: none"> ➤ Monitoring resistance (2.2 kOhm) measurable on primary line. ➤ Feedback contact (NC) actuated by the e-opener. ➤ For SD adapter: No fire alarm pending = no signal pending at terminals 9 and 10.
FSD does not lock.	<ul style="list-style-type: none"> ➤ Not all object keys are stored or secured. ➤ The latch does not actuate the RMK from the e-opener when the outer door has been closed. ➤ Door contact is not operated when the external door has been closed. ➤ Locking nose of a profile cylinder is not set correctly (in the key position "Secure", the microswitch [NC] must not be activated). ➤ See possible causes under point 1. 	<p>The BMZ or the SD adapter is responsible for unlocking and locking the FSD. If all the following criteria are met, it is locked:</p> <ul style="list-style-type: none"> ➤ Monitoring resistance (2.2 kOhm) measurable on primary line. ➤ Feedback contact (NC) actuated by the e-opener. ➤ For SD adapter: No fire alarm pending = no signal pending at terminals 9 and 10.

11. Decommissioning and disposal

This chapter describes the necessary actions for the safe decommissioning and disposal of the product. The service life of the product can be significantly increased by its intended use and regular maintenance and care.

11.1 Decommission product



CAUTION

The inner door lock and the operator's key must be removed during decommissioning. **The inner door lock must be handed over to the responsible fire brigade!** Otherwise, there are security risks!

Action	Guidelines
Decommissioning	Disconnecting the cabling between the FSD and the hazard alarm system
Cleaning	Clean FSD while regarding safety guidelines and safety data sheets of the installed products
Label	Apply labels for storage and safety on the product and packaging

11.2 Information on disposal

Element	Guidelines
Packaging	Consider regional guidelines for disposal
FSD	Demount product and separate the following materials: <ul style="list-style-type: none"> ➤ Synthetic materials ➤ Steel, tin ➤ Non-ferrous metals ➤ Electric/Electrical devices

WEEE registration number DE 97364822

11.3 Disposal points

Action	Guidelines
Returning to producer	If regulated by legislature or producer and reconciled with producer
Report to producer	Informing producer about disposal for statistic use

12. Service



12.1 Order details

Product designation	Item number
FSD basic with KRUSE VdS conversion lock and OSÜ	500001K
FSD basic prepared for profile cylinder with OSÜ	500001PZ
FSD basic incl. all-round sabotage protection with KRUSE VdS conversion lock and OSÜ	500006K
FSD basic incl. all-round sabotage protection, prepared for profile cylinder, with OSÜ	500006PZ

12.2 Accessories

Product designation	Item number
Key monitoring for FSD basic/flex-L (retrofit kit x 1, for self-installation)	500350
Rain protection for FSD basic (cover frame with rain protection)	500251
Combination frame for FSD basic/Combination frame OL for FSD basic (including space for KRUSE FB orientation light)	500270/500272
Combination rain protection for FSD basic/Combination rain protection OL for FSD basic (including space for KRUSE FB orientation light)	500275/500277
Wall frame for FSD basic	500281
Cavity wall adapter for FSD basic	500284
FB indicator plate "FSD" (foil sticker, 105 x 297 mm)	090103
FB indicator plate "FSD" (aluminium plate, 74 x 210 mm)	090203
Depth flange for FSD basic 3 mm/4 mm/6 mm	500290/500291/500292
DIN rail power supply for FSD heater	500310
Plug-in power supply for FSD heater	500300

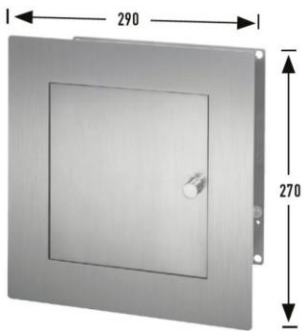
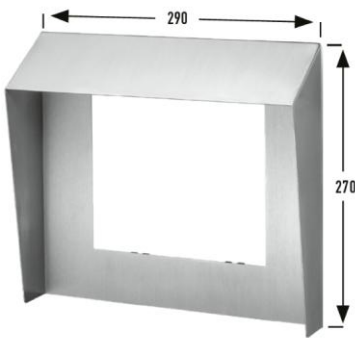
12.3 Dimensions of accessories (in millimetres)

Frame	Rain protection	Combination frame
Item 500250	Item 500251	Item 500270
		

We reserve the right to make technical modifications
07/2024

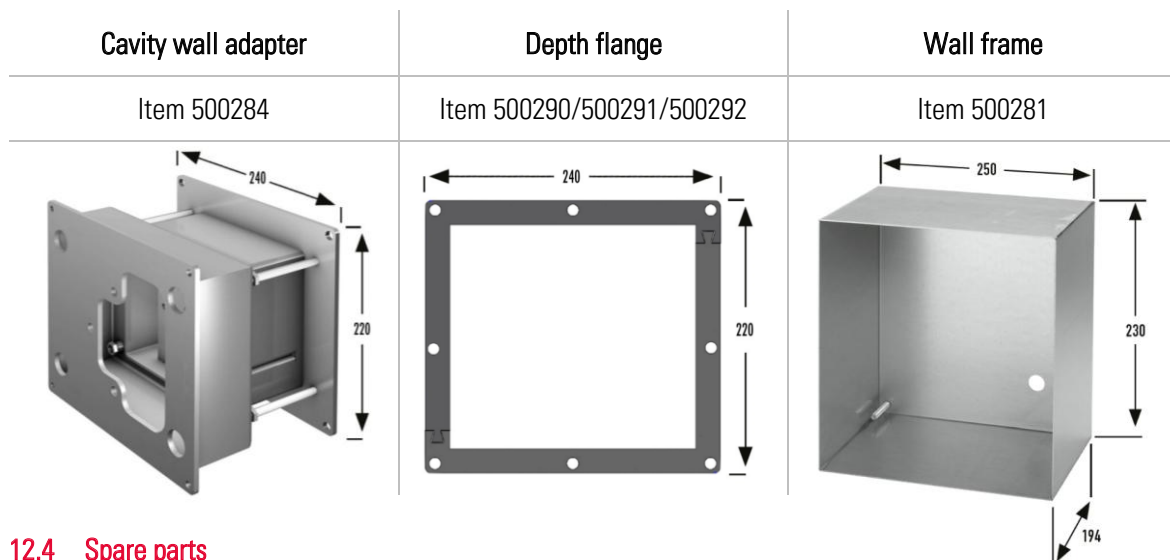

12.4 Spare parts

Product designation	Item number
Connection board (until 11/2018/from 11/2018)	105082-1/105082-2
Microswitch door (until 11/2018/from 11/2018)	105078/106080
All-round sabotage protection	105160
Drilling protection board (incl. heater)	105081
E-opener	025007
Microswitch OSÜ	105079
Latch	037004
External door (complete)	500200
Transfer board	105161
Connection cable (connection board SV6 <-> transfer board X1-A) (until 11/2018)	105154
Connection cable (connection board SV6 <-> transfer board X1-A) (from 11/2018)	105184

12.5 Product specifications

Dimensions (W x D x H)	see point 6.3 "Technical data/dimensions"
Total weight	depending on version 12-13 kg
Protection type	IP44
Cable cross-section equipotential bonding (Connection on the mounting flange)	4 mm ²
Cable connection	1.5 mm ²
Recommended profile semi-cylinder	max. 30/10
Total length of profile semi-cylinder with key	See point 6.3 "Technical data/Maximum installation length of the OSÜ"
Classification	FSD Class 3
Environmental Class	IV

We reserve the right to make technical modifications
07/2024

Electrical specifications

Operating voltage depot	10-30 V DC
Operating voltage heater	10-30 V AC/DC
Current consumption depot	approx. 330 mA (at 12 V DC) approx. 150 mA (at 24 V DC)
Current consumption heater	approx. 300 mA (at 12 V DC) approx. 150 mA (at 24 V DC) (max. inrush current: 3 A)
Indication resistor (internal)	approx. 2.2 k Ω \pm 5%
Internal resistance depot (grey/pink)	approx. 150 k Ω
Internal resistance heater (black/purple)	approx. 5-10 Ω (depending on outside temperature; values may vary slightly)
Internal resistance of drilling protection per circuit	approx. 5-15 Ω
Internal resistance all-round sabotage protection	approx. 15-30 Ω

12.6 Support

KRUSE Sicherheitssysteme GmbH & Co. KG

Technical Support

Phone: +49 4174 592-44

Email: support@kruse-sicherheit.de

13. FSD operation Information

Please refer to the VdS information on the operation of keydepots (VdS 5005) when using the KRUSE FSD. The guideline is included as an accessory pack.

14. Edits index

Rev. 1.0	December 2018	Creation
Rev. 2.0	October 2023	Basic rework
Rev. 2.1	July 2024	Small change-ups

15. Questions left?

Give a call to our support staff:

Tel.: +49 4174 592-44

Email: support@kruse-sicherheit.de

Informationen zum

Betrieb von Schlüsseldepots

Feuerwehrschlüsselkästen (FSK) werden seit dem Ende der siebziger Jahre in Verbindung mit Brandmeldeanlagen (BMA) eingesetzt, um der Feuerwehr bei einer Brandmeldung den Zugang zu einem Objekt zu ermöglichen. Zwischenzeitlich wurde die Bezeichnung Feuerwehrschlüsselkasten in **Schlüsseldepot (SD)** geändert. SD können auch bei anderen Anwendungen, z. B. gemeinsam mit VdS-anerkannten Einbruchmeldeanlagen (EMA), eingesetzt werden.

Um Probleme im Hinblick auf die Installation, die Überwachung, den Betrieb sowie die Instandhaltung zu vermeiden, sind folgende Punkte zu beachten:

- Wird ein SD installiert, so kann die Aufbewahrung von Gebäudeschlüsseln in diesem SD für den Versicherungsort eine **Gefahrerhöhung** darstellen (die – obschon gesicherte – Lagerung des Objektschlüssels in unmittelbarer Nähe zum Objekt begünstigt prinzipiell den Eintritt eines Schadens).
- Der Einbau eines SD nach Abschluss des Versicherungsvertrages muss dem Versicherer angezeigt werden. SD sollten entsprechend den anerkannten Regeln der Technik hergestellt, geplant, eingebaut und instandgehalten werden.

VdS-anerkannte SD sind geprüft und zertifiziert (VdS 2105) und entsprechen den anerkannten Regeln der Technik (ein SD 3 erfüllt die Anforderungen an FSD 3 gemäß DIN 14675). Planung, Einbau, Betrieb und Instandhaltung sind in den VdS-Richtlinien VdS 2350 beschrieben.

Wenn die Regeln nicht eingehalten werden, kann der Versicherer den Versicherungsschutz für Schäden durch Einbruchdiebstahl versagen. Dies kann der Fall sein, wenn der Zutritt zum Gebäude mithilfe des aus dem SD entwendeten (richtigen) Schlüssels erfolgte. Dies gilt insbesondere dann, wenn ein SD der falschen, d. h. einer zu niedrigen Klasse installiert wurde und der Schlüssel für den Einbruch benutzt wurde (zur Zuordnung von SD und Schlüsseln verschiedener Wertigkeit siehe VdS 2105, Abs. 4).

- Für die Innentür VdS-anerkannter SD dürfen ausschließlich VdS-anerkannte Schließungen verwendet werden. Diese Schließungen dürfen nicht gleichzeitig anderen Anwendungen bzw. Benutzergruppen dienen. Bei Verwendung von SD in unterschiedlichen Anwendungen bzw. unterschiedlichen Nutzergruppen (Feuerwehr, Wachdienst, Reinigungsdienst) sind unterschiedliche Schließungen einzusetzen. Dabei ist sicherzustellen, dass Nutzer einer Gruppe keinen Zugriff auf Schloss oder Schlüssel der SD anderer Nutzergruppen erlangen können.
- Die VdS-Anerkennung von Umstellschlössern bezieht sich jeweils auf die **geprüfte Einheit von Schloss und Schlüssel**, die gemeinsam geprüft und anerkannt wird. Auswirkungen auf die Funktion bei anderer Verwendung (unter Umständen Fehlfunktionen, wenn Schlösser mit „fremden“, nicht überprüften Schlüsseln betätigt werden) sind nicht auszuschließen und liegen allein im Verantwortungsbereich des Betreibers.

- SD müssen, um die sichere Funktionsfähigkeit des SD zu erhalten, regelmäßig instandgehalten werden.

Hinweis: Bei der Instandhaltung müssen je nach Anwendungsbereich des SD die Instandhaltungsdienste von Einbruchmeldeanlagen und/oder Brandmeldeanlagen sowie der Schlüsselträger (z. B. Feuerwehr) anwesend sein, damit kostenintensive Falschmeldungen vermieden werden.

- Je nach Anwendung gehören SD und der zugehörige Adapter definitionsgemäß entweder zur BMA oder zur EMA. Näheres hierzu ist VdS 2105 zu entnehmen.
- Sofern die für das SD vorgesehene Überwachung aus technischen oder organisatorischen Gründen nicht mehr sichergestellt ist, wird dringend empfohlen, die Objektschlüssel unverzüglich zu entnehmen, um den Versicherungsschutz nicht zu gefährden.

Weiterhin sollte das Schloss der Innentür des SD vom Schlüsselträger (z. B. Feuerwehr) oder dessen Beauftragten ausgebaut werden. Falls das Schloss der Innentür bei einem nicht ständig überwachten SD in diesem verbleibt, kann die Schließung des Schlosses Unbefugten unter Umständen bekannt werden, die sich dann unberechtigt Zutritt zu allen Objekten mit dieser Schließung verschaffen könnten.

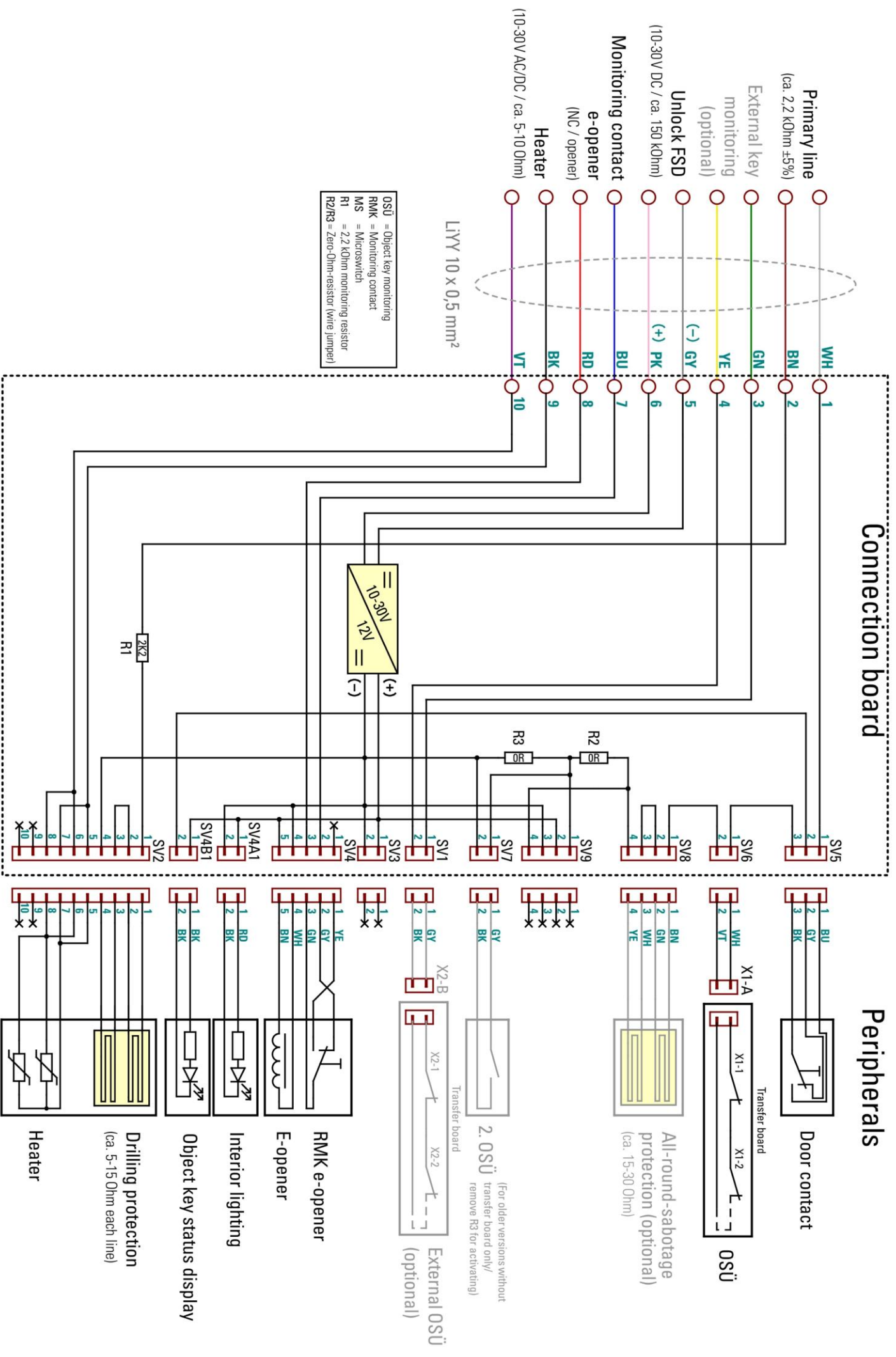

Connection board

Peripherals

Primary line
(ca. 2,2 KOhm ±5%)

External key monitoring (optional)

Unlock FSD
(10-30V DC / ca. 150 KOhm)

Monitoring contact e-opener (NC / opener)

Heater
(10-30V AC/DC / ca. 5-10 Ohm)

LiYY 10 x 0,5 mm²

OSÜ = Object key monitoring
RMK = Monitoring contact
M.S. = Microswitch
R1 = 2,2 KOhm monitoring resistor
R2/R3 = Zero-Ohm-resistor (wire jumper)

